

ALP-2000

REV	DESCRIPTION	PREP BY/DATE	CHECK BY/DATE

PROPRIETARY AND CONFIDENTIAL
 THE INFORMATION CONTAINED IN THIS DRAWING IS THE SOLE PROPERTY OF RES-Q-JACK INC. ANY REPRODUCTION IN PART OR AS A WHOLE WITHOUT THE WRITTEN PERMISSION OF RES-Q-JACK INC. IS PROHIBITED.

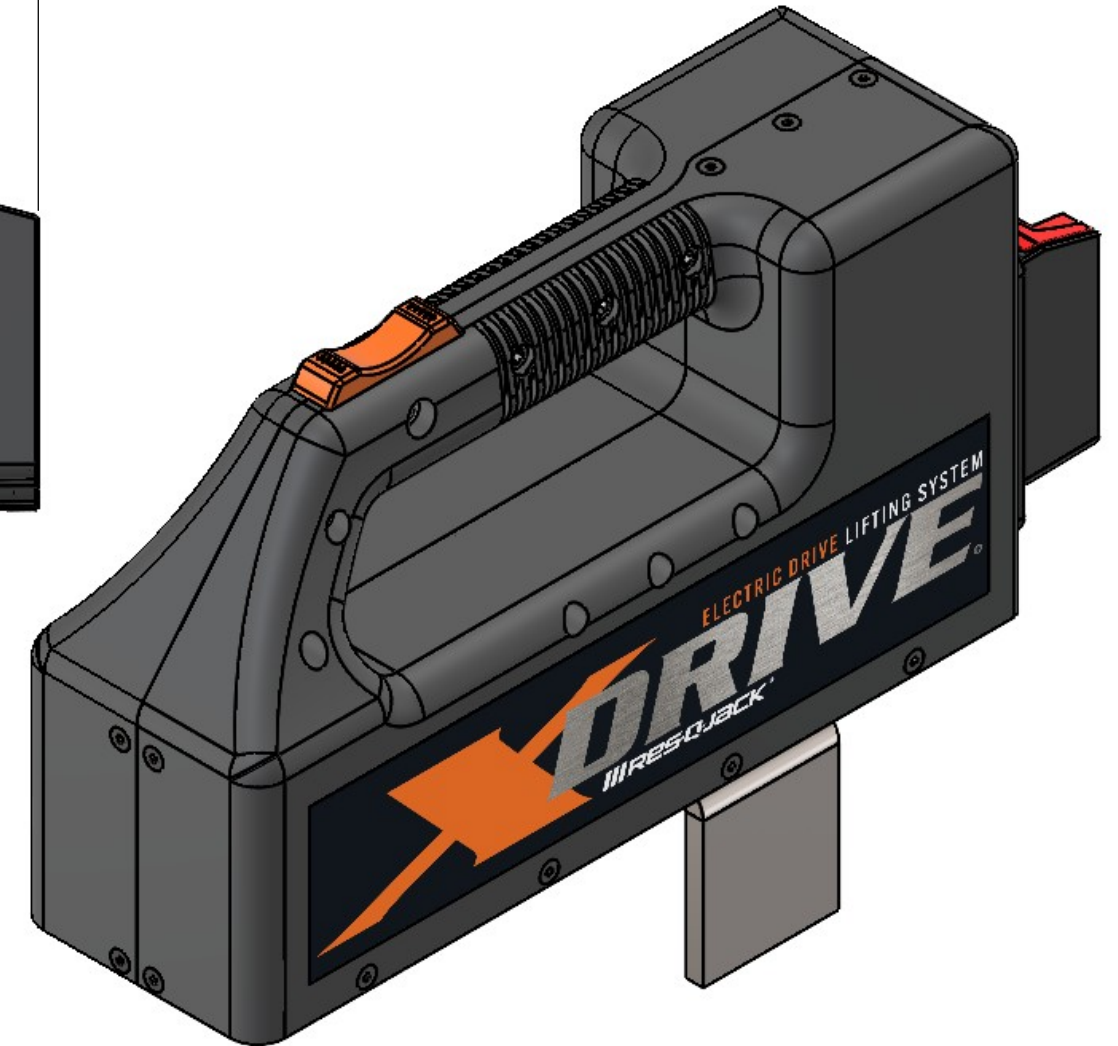
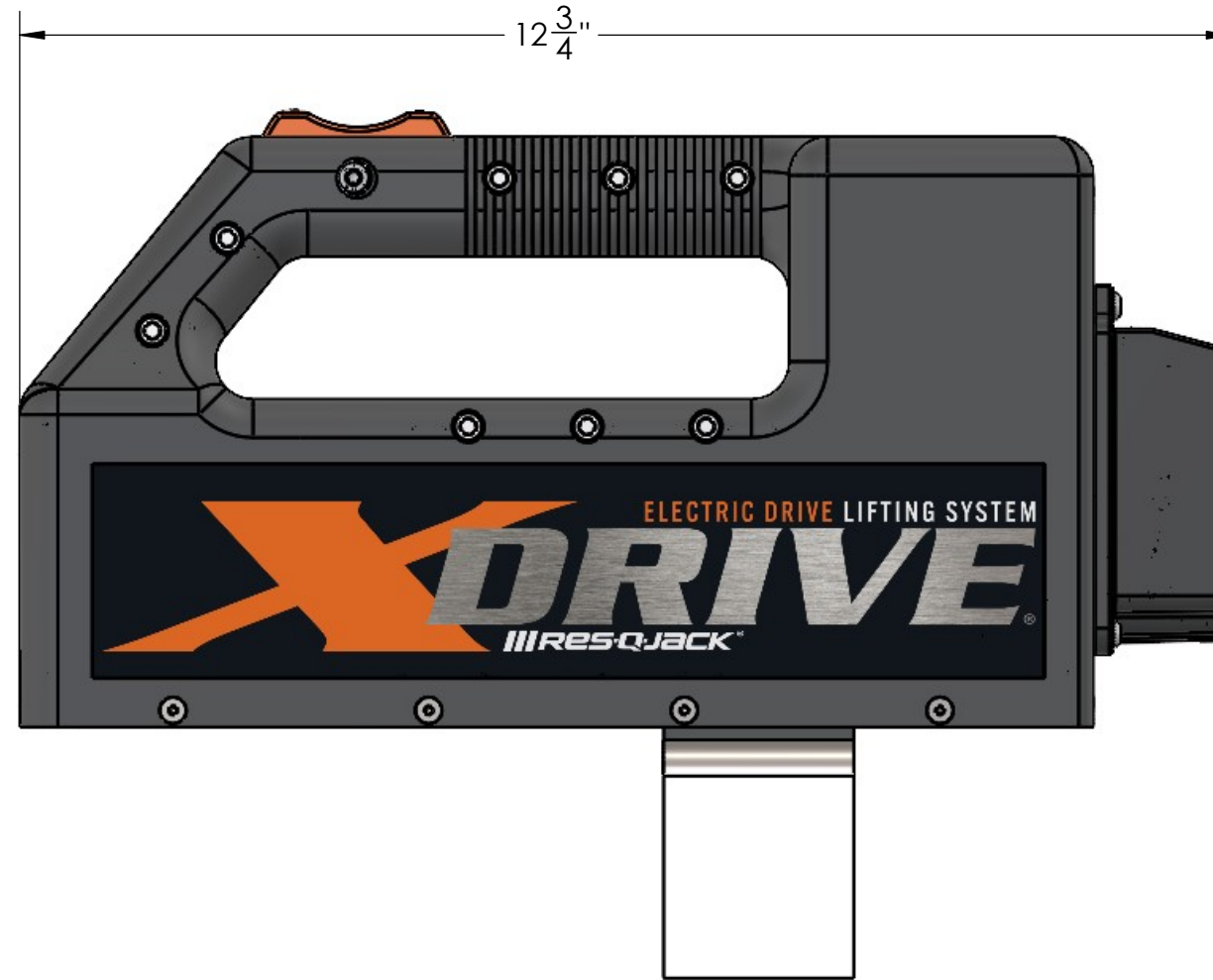
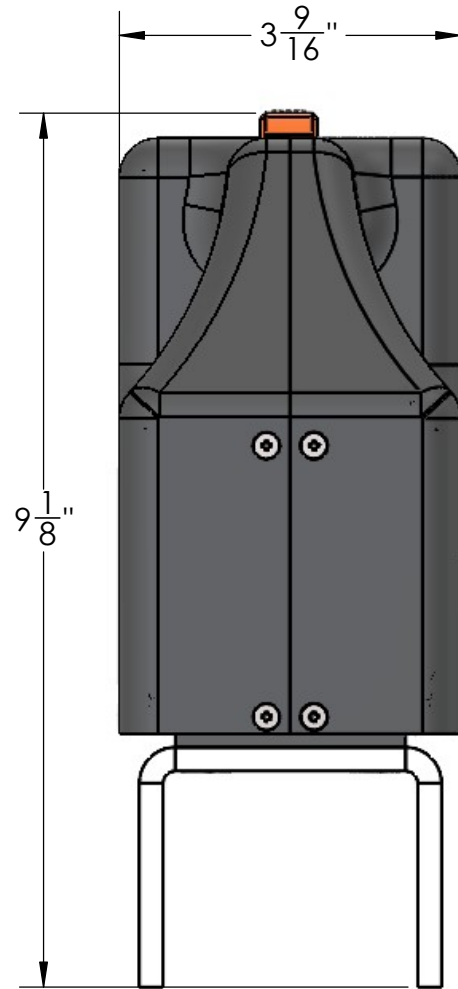

TECHNICAL SPECIFICATIONS;
 -LOAD LIMIT 6000 LBS
 -AVERAGE LIFT RATE: 5.5"/MINUTE
 -BATTERY COMPATIBILITY
 MILWALKEE 18V
 OR
 DEWALT 20V
 OR
 MAKITA 18V
 -5 WATT AREA LIGHTING WHEN BATTERY ATTACHED
 -MAGNETIC HOLD TO JACK
 -ALUMINUM AND STAINLESS STEEL FRAME
 -STAINLESS STEEL HARDWARE
 -PROPRIETARY HIGH-PERFORMANCE POLYMER CASE
 ~10.7LB WITHOUT BATTERY
 *Dimensions are ±1/16"

MATERIAL:		RES-Q-JACK™		
DIMENSIONING AND TOLERANCING UNLESS OTHERWISE SPECIFIED: DIMENSIONS ARE IN INCHES TOLERANCES: FRACTIONAL ±1/32 ANGULAR: MACH ± 0° 30', BEND ± 1° TWO PLACE DECIMAL ±0.01 THREE PLACE DECIMAL ±0.005		INTERPRET DRAWING PRACTICES IN ACCORDANCE WITH ASME Y14.100. INTERPRET DIMENSIONING AND TOLERANCING IN ACCORDANCE WITH ASME Y14.5-1994.		
FINISH:		TITLE: X-DRIVE		
HEAT TREAT:		DWG. NO. ALP-2000		
ENG./DATE: NICK H	MFG./DATE:	OTHER/DATE:	SCALE: 1:4	SIZE: B
			SHEET 1 OF 3	